

DIMENSIONAL TOLERANCE

IT MAY BE THE “MISSING LINK” IN YOUR ANILOX PERFORMANCE

■ By Art Ehrenberg

Editor's Note: This is the second of a two-part article on dimensional tolerances. Part 1 was published in January FLEXO, page 41.

The cleaning, care and maintenance of anilox rolls are very important, as are the engraving, lasers and ceramic coatings. No matter what cell geometry, line screen or depth-to-opening you're using, however, or what type of laser was utilized to perform the engraving, or what level of quality the ceramic is or how well you clean and maintain your rolls, these rolls will not perform without proper dimensional stability.

Part 1 of this article discussed the importance of proper dimensional tolerances of bearings, bearing surfaces and gear steps on anilox rolls. It also covered some basics on balancing and some maintenance issues when installing and removing gears and bearings. In Part 2 some more very important dimensional tolerance issues will be discussed: total indicated runout (TIR), concentricity, circularity and cylindricity.

Total Indicated Runout (TIR)

Total indicated runout describes how certain features of a part run true to the absolute axis of the part. The term “TIR” utilized in the anilox arena typically is a numerical expression of how the bearing surfaces on the shafts of a roller run round or concentric to each other and the engraved area of the roll body when rotated. The term is often confused with “circularity” and “concentricity.”

The term “circular runout” defines the circular condition of a single step or plane of a single-part feature to a datum axis (see Figure 1). The difference between “circular” and “total runout” is described in Figure 2. The engraver is most concerned with the TIR between the bearing surfaces and the engraved body. This is where lack of dimensional stability typically

has the most effect on the roll's ability to evenly apply a liquid film and pressure to the printing plate. A TIR measurement between the bearing surfaces and the engraving is taken to ensure that the roll does not rotate in an egg shaped or eccentric condition from its axis when mounted during anilox processing or in the press. TIR that is out of tolerance can cause cylinder bounce, harmonic vibrations and uneven impression of the anilox to the plate, which can result in dot gain in areas and/or light and dark printing streaks.

TIR is usually measured in one of two ways. In most instances, the roll's bearing surfaces are rested in a slot made by placing two precision bearings closely together in a housing (see photo), or in a set of metal blocks with a “V” cut out of them. These set-ups are called “bearing

One way of measuring TIR is by resting the roll's bearing surfaces in a slot made by placing two precision bearings closely together in a housing.

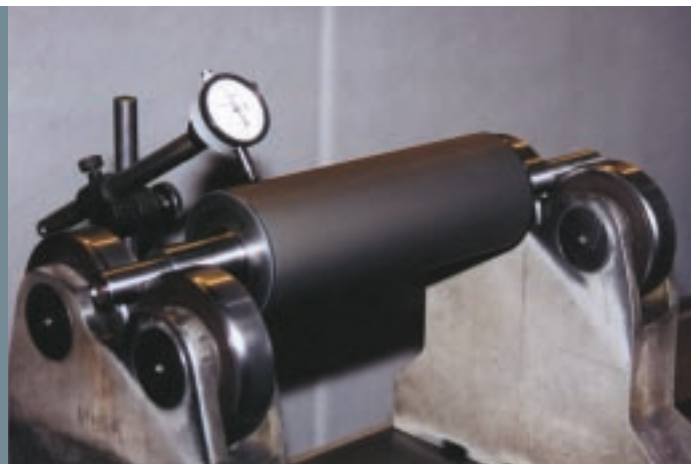

CIRCULAR RUNOUT

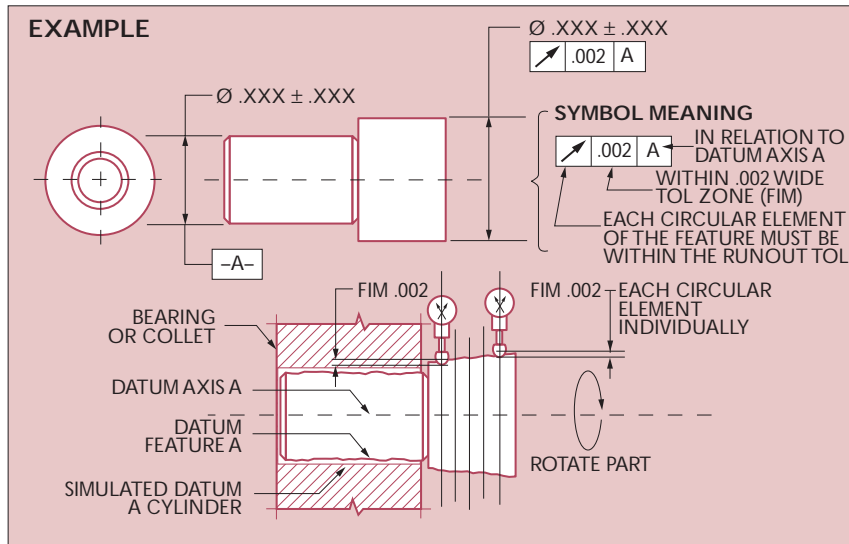

Figure 1

blocks” or “V” blocks, respectively. After mounting in the blocks, a precision dial indicator is used to measure the TIR on the circumference of the roll.

With this method of TIR measurement, “circularity” or “roundness” of the bearing surface must be taken into consideration. Out-of-round conditions, flat spots or burrs from scratches and dings on the bearing shaft surface could exaggerate or even cancel out the true TIR reading. This is due to the fact that there are two areas of the bearing surface touching two surfaces of the bearings or “V” blocks simultaneously. If you are using bearing blocks, check the bearings periodically for accuracy, and replace when necessary. Bearing and “V” blocks also should be on a level surface when performing TIR checks.

Another method of measuring TIR is to hold and rotate the roll between two centers in a lathe-like fixture or in a conventional lathe between a chuck and a center. This set-up will give the truest reading of TIR between the bearing surfaces and the engraved body, because you no longer have the influence of the bearings in the bearing blocks. Check the circularity of the steps. After the roll is set in one of the

described methods, a dial indicator is put against the roll body and the roll rotated to obtain the variance reading of how much the roll body runs in and away from the center axis of the roll.

It is a good idea for converters to be capable of checking TIR in and out of their presses. If you choose to purchase and use a dial indicator, purchase a high-quality brand, and make certain not to introduce it to impact. They are sensitive instruments and must be maintained properly in order to give correct readings.

Also be certain to acquire a high-quality, rigid base for holding the indicator.

The measurement of TIR on rolls with internal bearings is much the same, but must be performed on a precision shaft either from the OEM or one manufactured to OEM tolerances. With these rolls, there should be no locking device holding the roll to the shaft, which applies undue pressure to the core. This can seat the roll in an undesirable position because of the bearing tolerance. The shaft ends should be running true to the bearing surface areas of the shafts to no more than .0002-inch as a reference point. Place a dial indicator at 90 degrees to the roll axis pointing directly downward over the center of the roll.

Generally acceptable TIR tolerances for the engraved body to the bearing surfaces:

Corrugated	.0015” to .0025”
Preprint	.001” to .0015”
Film, Foil, Other	
Wide Web	.0005” to .0015”
Tag, Label,	
Envelope	.0005” to .001”

The TIR tolerance that is specified for the press you have is different from the TIR that is acceptable during the anilox manufacturing process. Take a wide web roll, for

TOTAL RUNOUT

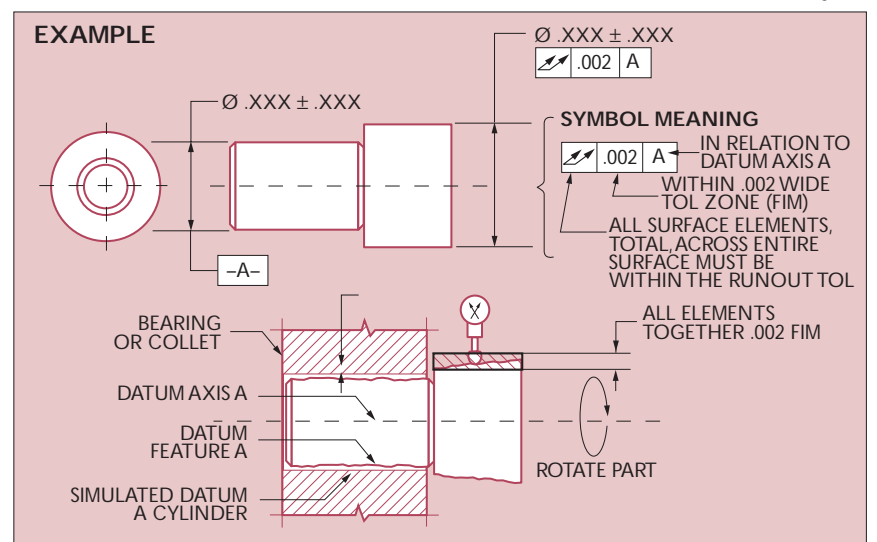

Figure 2

example, that has a TIR tolerance of .0015-inch. Let's assume that a roll is circularly round but has a slightly bent shaft, causing a TIR of .001-inch on the engraved area prior to engraving. If the TIR cannot be eliminated by manipulation of the laser's chuck and tailstock devices, a portion of the roll surface will be moving into and away from the laser beam as much as .001-inch. If the engraving is going to be a 400 L/S at a 3.3 BCM, the engraving depth will be about 13 microns, or roughly .0005-inch. If the roll body is moving into and away from the laser beam by .001-inch, one side of the roll's engraving will be far too deep and the other far too shallow. This results in thick and thin ink films on different planes of the engraving, which will cause light and dark printing across the web. So, the roll's TIR tolerance to run in the press is not necessarily acceptable to use during anilox processing.

Circularity (Roundness)

Along with TIR, we must also consider the roundness of the roll body or the engraved diameter in particular. This can be a tricky subject, and the associated terminology often varies or is misapplied.

Circularity is described in the dictionary a couple of different ways, depending on the dictionary you use. Two of those descriptions are "the quality or state of being circular" and "the roundness of a two-dimensional figure." Circularity is a tolerance zone formed between two concentric circles where the surface periphery at any cross section perpendicular to the axis must fall within the specified tolerance. An example of a specific tolerance can be seen in Figure 3.

Cylindricity applies to the entire cylinder length, not just one area (see Figure 4). Circularity and cylindricity have to be considered with concentricity (see Figure 5) in order to get a better picture of the roll's dimensional stability. These geometric measurements will also affect the roll's ability to engrave evenly around the circumference.

In the machining and/or grinding stages of anilox production, very special care must be taken to address TIR, circularity, cylindricity and concentricity in order for the roller to meet high quality standards. In manual machining or lathing, it is possible for a roller to not be circular and for this condition to not be revealed by the use of a dial indicator

alone. This usually occurs when machine components such as head stock bearings and centers contain run-out that is out of tolerance. Therefore, a couple of measuring methods must be applied to be certain you are within the allowable tolerances of each of these conditions.

When dealing with tolerances, consider all the components' toler-

CIRCULARITY

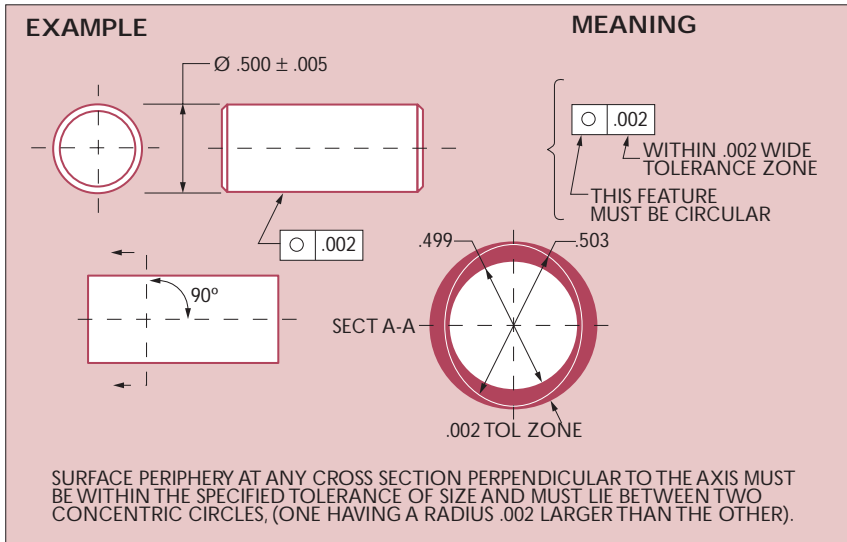

Figure 3

ances that will affect the overall performance of the anilox roll. The anilox bearing surface has a specific size and “runout” tolerance, but so does the bearing. Therefore, make certain that both components are all in tolerance in order to achieve the expected results.

You must stack tolerances to get the true picture of the total dimensional stability. Take a roll that runs on internal bearings, for example. This type of roll will be fit to a shaft and will either use the bearings for the rotation of the roll or use them simply for insertion of the shaft that drives the roll. With this set-up, multiple components must be in tolerance. All the tolerances must be realistically combined to get the total “stack tolerance.”

With an internal bearing arrangement, you have the size tolerance of the roll’s bore (I.D., or inner diameter) that the bearing goes into, plus its allowable circular tolerance. You have the tolerance of the run-out in the bearing itself and the bearing inner-race bore diameter plus the tolerance of the bearing surface diameter on the shaft that is inserted through the bearing bore. Then you have to consider the run-out tolerance of the shaft as it is mounted in the press.

In order to get the true picture of

the maximum allowable run-out condition of the engraved portion of the anilox roll, consider all these tolerances and how they may add or “stack” together. So if the roll bearing is allowed to run-out .0005-inch, and the shaft .0005-inch, and the diameter tolerance of the shaft and the bore tolerance of the bearing inner race and the bore tolerance of the roll body are considered, there could realistically be a run-out or TIR of .0015-inch or more.

The stability of all the dimensional tolerances of anilox rolls is impor-

tant. Often many of these dimensions are neglected, especially during bearing and gear removal, and the effects of their being out of tolerance are not always understood. The anilox roll supplier is responsible for the roll’s overall performance, so it must have all the tolerances to the correct specifications; otherwise, the roll’s performance will be compromised no matter how precise the engraving was performed.

As flexographic printing continues in an upward spiral to new quality heights, these dimensional tolerances are getting tighter and tighter. We must understand the dynamics of the tolerances, have the equipment and technique to measure them and hold them to their acceptable limits. Printers must understand how the handling of these rolls can affect the tolerances and how out-of-specification tolerances can affect the printing requirements. 

About the author...

Art Ehrenberg is vice president of operations for Harper Corporation’s Green Bay, WI division. He has held numerous titles within Harper’s organization, including plant manager at the company’s Charlotte, N.C., headquarters from 1990 to 1996. He has been associated with the flexographic printing industry for 21 years.

Note: The drawings in this article were reprinted from “A Pocket Guide To Geo-Metrics II,” pp. 12, 13, 18, 19, 17, with the permission of Pearson Edwards Inc., Upper Saddle River, NJ.

CYLINDRICITY

Figure 4

